



QUICK TIPS

- Position all recyclable containers in visible areas next to trash cans.
- Clearly mark all containers for recyclables (cardboard, cans, paper, etc.). Make signs bilingual or use graphics as needed.
- Educate employees and attendees on the where, what, and whys of recycling.
- Require suppliers to reduce packaging or use reusable packaging which is returned to supplier.
- Share collection or processing equipment with nearby venues or events.
- Add mandatory recycling language into contracts or add a disposal fee with a rebate for those who recycle.
- Use volunteers or staff to monitor recycling and trash cans. Help attendees select the appropriate can for their waste.
- Target educational materials to your audience.

Why Recycle?

The benefits of recycling can help save your business money, reduce pollution, and conserve natural resources.

Siskiyou County staff will work with you to develop the best recycling plan for your business.



SISKIYOU COUNTY DEPARTMENT OF GENERAL SERVICES

**190 GREENHORN ROAD
YREKA, CA 96097
PHONE: (530)842-8241
FAX: (530) 841-2800
MON—FRI
8:00 AM—5:00 PM**

WWW.CO.SISKIYOU.CA.US

For additional general information about recycling and waste reduction, visit the California Department of Resources Recycling and Recovery (CalRecycle) at www.calrecycle.ca.gov.





With the passage of Assembly Bill (AB) 341, businesses and public entities that generate four cubic yards or more of waste per week and multifamily dwellings with five or more units are required to recycle. The purpose of this new law is to reduce greenhouse gas emissions by diverting commercial solid waste from landfills and expand opportunities for recycling in California.

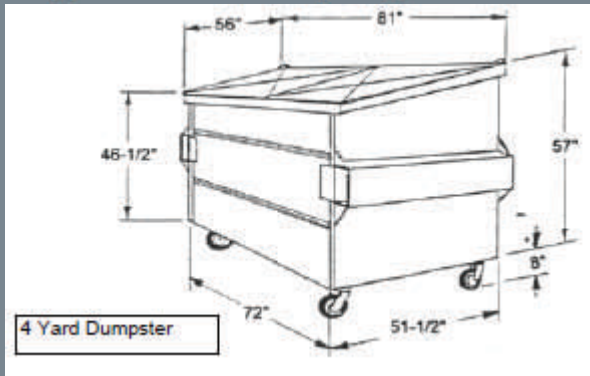

According to the 2008 Statewide Waste Characterization Study, the commercial sector generates nearly three-fourths of all solid waste in California, much of it readily recyclable. On July 1, 2012 California legislators passed AB 341.

If your business or public entity:

- Generates four (4) cubic yards of solid waste per week.
- OR**
- Is a multi-family dwelling with five (5) units or more.

Your business must do one of these:

- Separate and self-haul your recyclable materials.
- Subscribe to a recycling service.
- Arrange for pickup of recyclables.
- Donate recyclable materials.
- Compost or otherwise divert organic waste.
- Require tenants to source separate their recyclable materials.

Eligible recyclables may include:

- Beverage Containers (bottles & cans)
- Carpet
- Electronic devices
- Metal
- Organic Waste (food scraps, etc.)
- Paper and/or Cardboard
- Tires
- Universal Waste (batteries & bulbs)
- Used Oil and/or Paint

Authority cited:
Section 40502,
Public Resources
Code. Reference:
Section 42649.1,
Public Resources
Code.



§18837. Mandatory recycling of commercial solid waste by businesses.

On and after July 1, 2012, a business shall take at least one of the following actions in order to reuse, recycle, compost, or otherwise divert commercial solid waste from disposal:

(1) Source separating recyclable and/or compostable materials from the solid waste they are discarding and either self-hauling, subscribing to a hauler, and/or otherwise arranging for the pick-up of the recyclable and/or compostable materials separately from the solid waste to divert them from disposal.

(2) Subscribing to a recycling service that may include mixed waste processing that yields diversion results comparable to source separation.

To comply with §18837(a), property owners of commercial or multi-family complexes may require tenants to source separate their recyclable materials. Tenants must source separate their recyclable materials if required to by property owners of commercial or multi-family complexes.